



Submittal For Single Wall Spiral With Non-Gasketed Fittings

Hranec Sheet Metal Inc.
763 McClellandtown Road
Uniontown PA 15401

www.hranec.com
Fax: 724-437-2233
Ph.: 724-437-2211

HRANEC CORP.



SUBMITTAL **Single Wall Spiral**

INDEX

| | |
|------------|--|
| PAGE 1 | FABRCATION FORM |
| PAGE 2 | SPECIAL NOTES |
| PAGE 3 | PRESSURE CLASSES |
| PAGE 4 | CONNECTIONS |
| PAGE 5 | SPIRAL DUCTWORK |
| PAGE 6 | GORE-LOCK ELBOWS |
| PAGE 7 | REDUCERS |
| PAGE 8 | ROUND END SADDLE TAP |
| PAGE 9 | END CAPS |
| PAGE 10 | OFFSETS |
| PAGE 11 | RECTANGULAR END SADDLE TAPS |
| PAGE 12 | ROUND TAPS OFF FLAT SURFACES |
| PAGE 13 | TEE'S & CROSSES |
| PAGE 14 | ROUND DAMPERS |
| PAGE 15 | DUCT LINER INSTALLATION APPLICATION DETAIL |
| PAGE 16-17 | LINER SPECS |

SPECIAL NOTES:

- **SUBMITAL** = INCLUDES ALL AVAILABLE MATERIALS, CONNECTIONS AND PRESSURE CLASSES REFERANCE OUR FABRICATION FORM FOR PROJECT SPECIFIC DUCTWORK INFORMATION. LISTED AS PAGE 1
- **FABRICATION** = ALL DUCTWORK IS FABRICATED PER SMACNA STANDARDS AND / PROJECT SPECIFICATIONS
- **MATERIALS FOR PAINTING** = RECOMMENDED MATERIAL FOR PAINTED SPIRAL DUCT = PAINT GRIP, HOWEVER GALVANIZED G90 CAN EASILY BE PAINTED WITH EXTRA PREP WORK.
- **PREP BEFORE PAINTING** = WE RECOMMENDED WIPING DOWN MINIMAL EXCESS LUBRICANT TWICE BEFORE PAINTING WITH DRY RAGS. IN ADDITION, WIPE DOWN WITH NO RINSE PREPAINT CLEANER #13158 (SHERWIN WILLIAMS) BEFORE APPLYING TWO COATS METAL PRIMER.
- **PAINT AND PRIMER** = ALL PRIMER AND PAINT SHOULD BE LABELED TO ADHERE TO METAL PAINTING APPLICATIONS. FOLLOW PAINT MANUFACTURERS APPLICATION PROCEDURES, TEMERATURE, HUMIDITY, SURFACE PREP WORK, ETC.
- **CAUTION** = IF A STEEL CABLE HANGING SYSTEM IS USED TO SUSPEND DUCT WORK, DO NOT APPLY PAINT, LUBRICANTS, OR OTHER COATINGS TO THE HANGING SYSTEM. FOLLOW HANING SYSTEM MANUFACTURERS INSTRUCTIONS
- **TESTING** = OUR SPIRAL DUCTWORK HAS BEEN EXTENSIVELY AIR TESTED FOR LOW, MEDIUM, & HIGH PRESSURES.
- **SEAMS** = LONGITUDINAL SEAMS ARE ALL STITCH WELDED ON FITTINGS.
- **GAUGES** = METAL GAUGES ARE PRESSURE CLASS DRIVEN FROM LATEST SMACNA STANDARDS
- **SEALANT** = PROPER SEALING OF ALL COMPONENTS ESSPECIALLY CONNECTIONS. IS REQUIRED TO AVOID DARK AIR STREAKS AFTER INSTALLATION.
- **MATERIAL** = GALVANIZED, PAINT GRIP, SS304, SS316, PVC 4X4, ALUMINUM
- **WATER PROOF** = SPIRAL SEAM DUCT WORK IS NOT CONSTRUCTED TO BE WATER PROFF



PRESSURE CLASSES

POSITIVE PRESSURE

2005 SMACNA +10WG -6WG

| Diameter | Fittings | Spiral |
|----------|----------|--------|
| 3-9 | 28 | 28 |
| 9-14 | 28 | 28 |
| 15-18 | 26 | 26 |
| 19-24 | 24 | 26 |
| 25-42 | 22 | 24 |
| 43-60 | 20 | 22 |
| 61-66 | 18 | 22 |
| 67-96 | 18 | 20 |

ALUMINUM

2005 SMACNA +4WG -6WG

| Dia. | Fittings | Spiral |
|-------|----------|--------|
| 3-8 | 0.032 | 0.025 |
| 9-14 | 0.032 | 0.025 |
| 15-26 | 0.040 | 0.032 |
| 27-36 | 0.050 | 0.040 |
| 37-50 | 0.063 | 0.050 |
| 51-60 | 0.071 | 0.063 |

GALV, PG, SS, PVC ("Steel")

| HRANEC PIPE | | HRANEC FITTINGS | |
|-------------|-------|-----------------|-------|
| Size | Gauge | Size | Gauge |
| 4"-18" | 26 | 5"-20" | 24 |
| 20-28 | 24 | 22-36 | 22 |
| 30-38 | 22 | 38-50 | 20 |
| 40-48 | 20 | 52-60 | 18 |
| 50-58 | 18 | 62-70 | 16 |
| 60-70 | 16 | | |

ALUM

HRANEC PIPE HRANEC FITTINGS

| SIZE | GAUGE | SIZE | GAUGE |
|-----------|-------|-----------|-------|
| 4" - 40" | .040 | 4" - 40" | .040 |
| 42" - 70" | .050 | 42" - 70" | .050 |

- ALL GAUGE AND DIAMETER PIPE WILL BE SPIRAL SEAM
- ALL STEEL FITTINGS 24 GAUGE TO 20 GAUGE TO HAVE GORELOCK TRANSVERSE SEAM
- ALL STEEL FITTINGS 24 GAUGE TO 20 GAUGE TO HAVE STITCH WELD LONGITUDINAL SEAM
- ALL STEEL FITTINGS 18 GAUGE TO 16 GAUGE TO HAVE TACK WELDED AND SEALED TRANSVERSE SEAM
- ALL STEEL FITTINGS 18 GAUGE TO 16 GAUGE TO HAVE TACK WELDED AND SEALED LONGITUDINAL SEAM
- ALL ALUMINUM FITTINGS 50" AND SMALLER TO HAVE GORELOCK TRANSVERSE SEAM
- ALL ALUMINUM FITTINGS 50" AND SMALLER TO HAVE BUTTON LOCK LONGITUDINAL SEAM
- ALL ALUMINUM FITTINGS 52" AND LARGER TO HAVE BUTTON LOCK TRANSVERSE SEAM
- ALL ALUMINUM FITTINGS 50" AND SMALLER TO HAVE TACK WELDED AND SEALED LONGITUDINAL SEAM



CONNECTIONS AVAILABLE FOR ROUND DUCT AND FITTINGS

1. **SLIP FIT = RECOMMENDED INSTALLATION = COUPLING CONNECTIONS TO BE CAULKED AND SCREWED EVERY 10" AROUND THE DIAMETER**

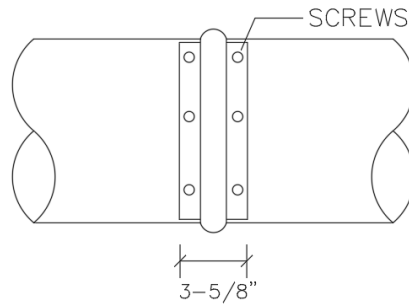

2. **SINGLE - WALL FLANGE = RECOMMENDED INSTALLATION = FLANGED CONNECTION TO BE GASKETED OR CAULKED AND SCREWED EVERY 10" AROUND THE DIAMETER**

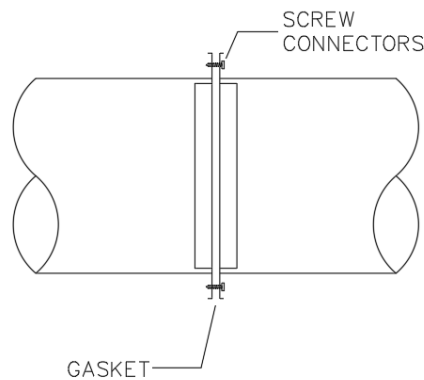

3. **ANGLE RING WITH OR WITHOUT BOLT HOLES= RECOMMENDED INSTALLATION= ANGLE RINGS WITHOUT BOLT HOLES TO HAVE FIELD FULLY WELDED CONNECTIONS WITH NO GASKET, ANGLE RINGS WITH BOLT HOLES TO BE GASKETED THEN NUT AND BOLTED USING THE BOLT HOLE PATTERN WITHOUT SKIPPING ANY HOLES. REFERENCE SMACNA FOR FULL INSTALLATION GUIDLINES**

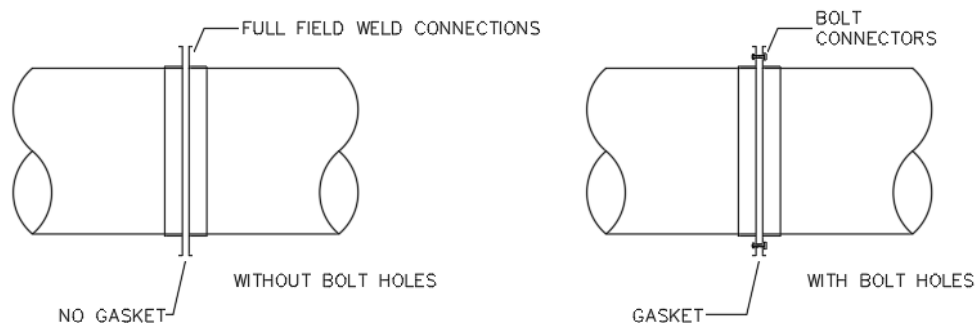

SPIRAL DUCT

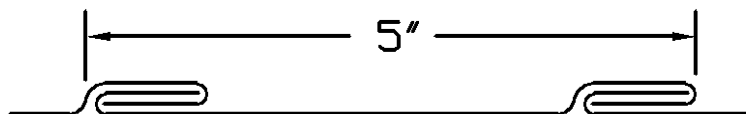

LATERAL SECTION OF 4-PLY PRESSURE PROOF
SPIRAL SEAM

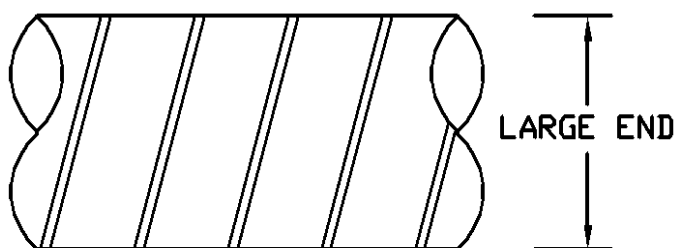

NOTES:

- A. AVAILABLE IN EVEN SIZES 4"Ø THROUGH 70" Ø
- B. AVAILABLE IN ODD SIZES 5"Ø, 7", & 9"Ø
- C. LENGTHS - 6" THROUGH 240" (STANDARD 120")



GORE-LOCK ELBOW

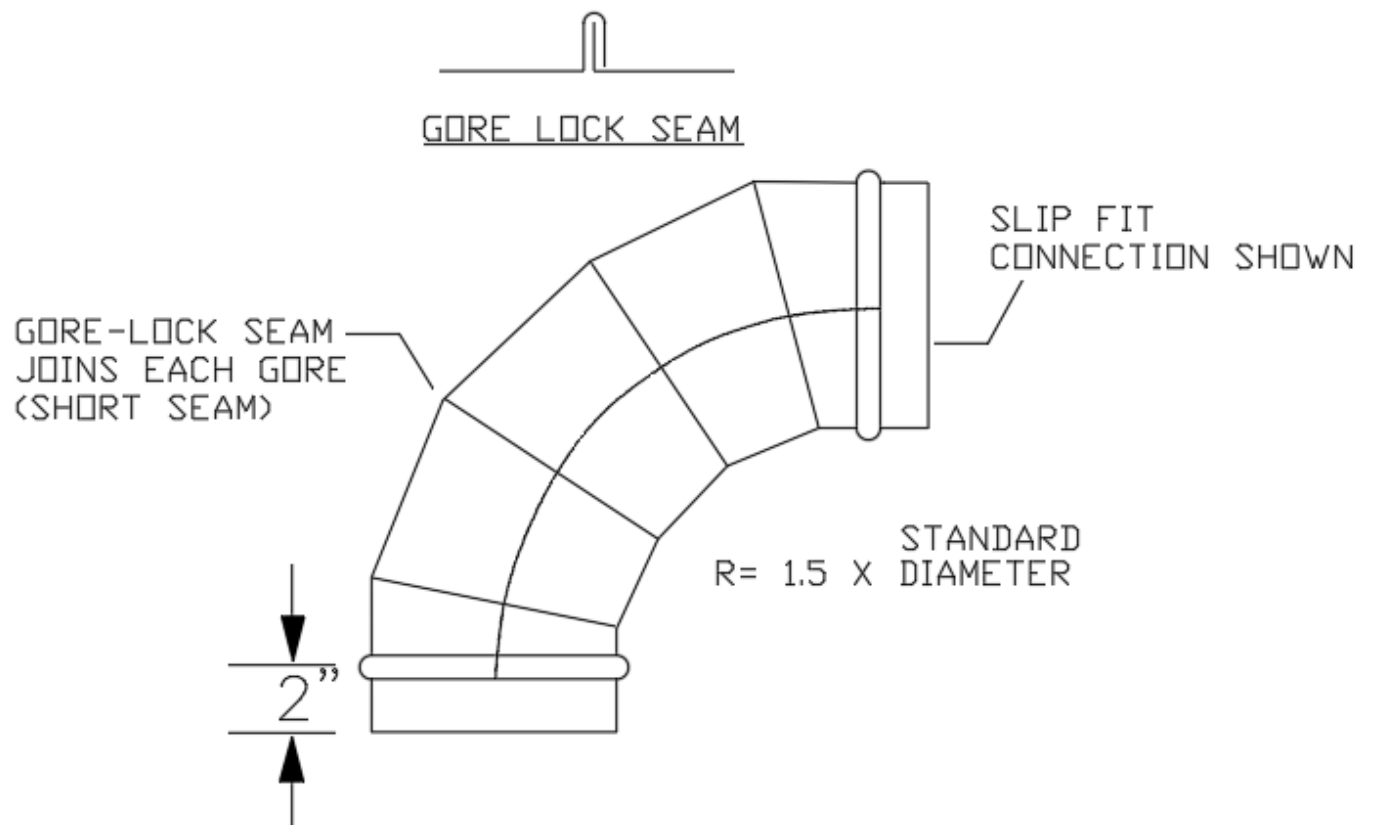

- AVAILABLE IN 5° THROUGH 120°
- SHORT RADIUS ELBOWS ARE CONSIDERED 1 X DIAMETER AND IS CENTERLINE
- OTHER RADIUS ELBOWS ARE AVAILABLE



REDUCERS

CONCENTRIC REDUCER

$$X = \frac{D_1 - D_2}{2} \times 3$$

4" Minimum

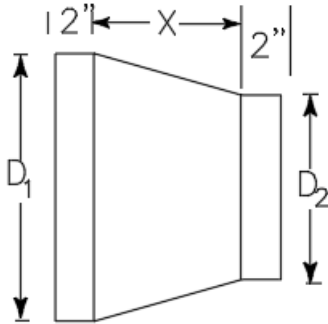

ECCENTRIC REDUCER

$$X = \frac{D_1 - D_2}{2} \times 3$$

4" Minimum

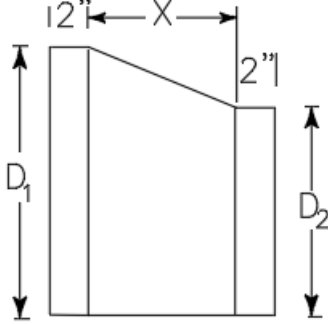

OFFSETTING REDUCER

$$X = O \times 3$$

4" Minimum

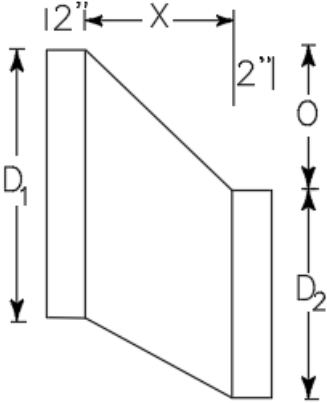

ROUND END SADDLE TAPS

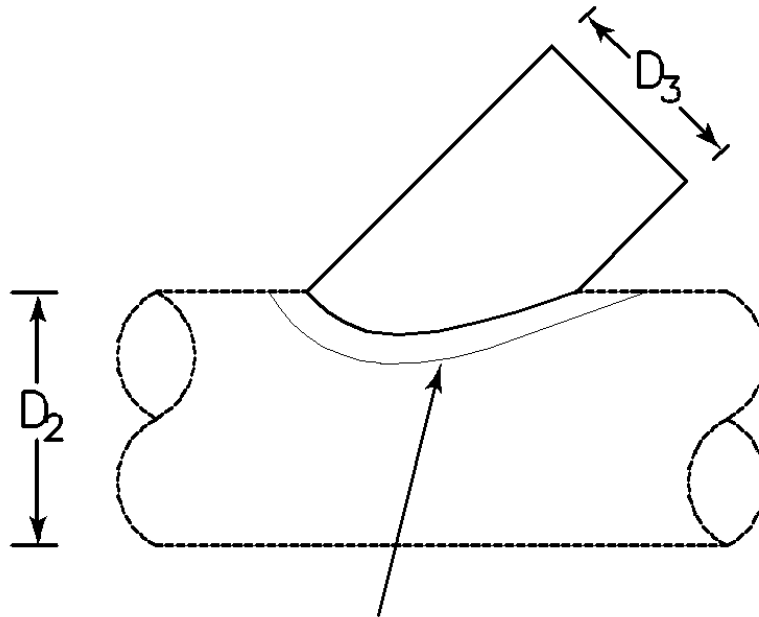

4"-16"= 1/2" FLANGE OUT
 18" AND ABOVE= 2" PLATE WITH 1/2" HEM IN

- STANDARD 45 DEGREE & 90 DEGREE ANGLES. ALTERNATE ANGLES AVAILABLE.
- 90 DEGREE CONICAL AVAILABLE.
- HIGH EFFICIENCY SHOE STYLE AVAILABLE

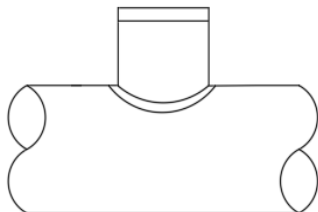

90 DEGREE SADDLE

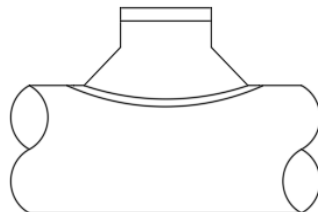

CONICAL SADDLE

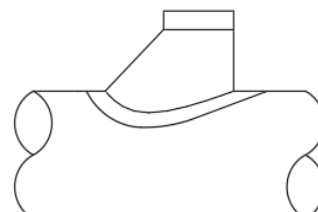

SHOE STYLE SADDLE



END CAPS

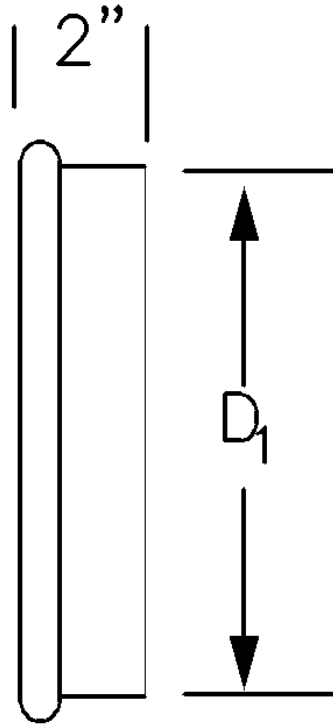

OFFSETS

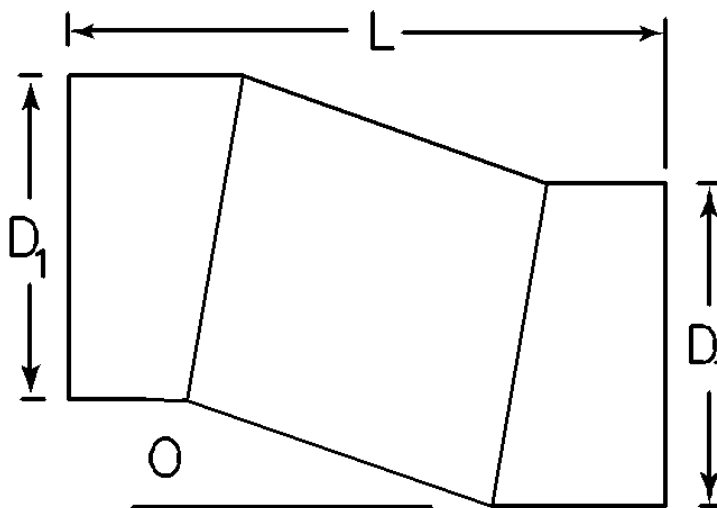

- LENGTH TWO OR THREE TIMES THE OFFSET



RECTANGULAR END SADDLE TAPS

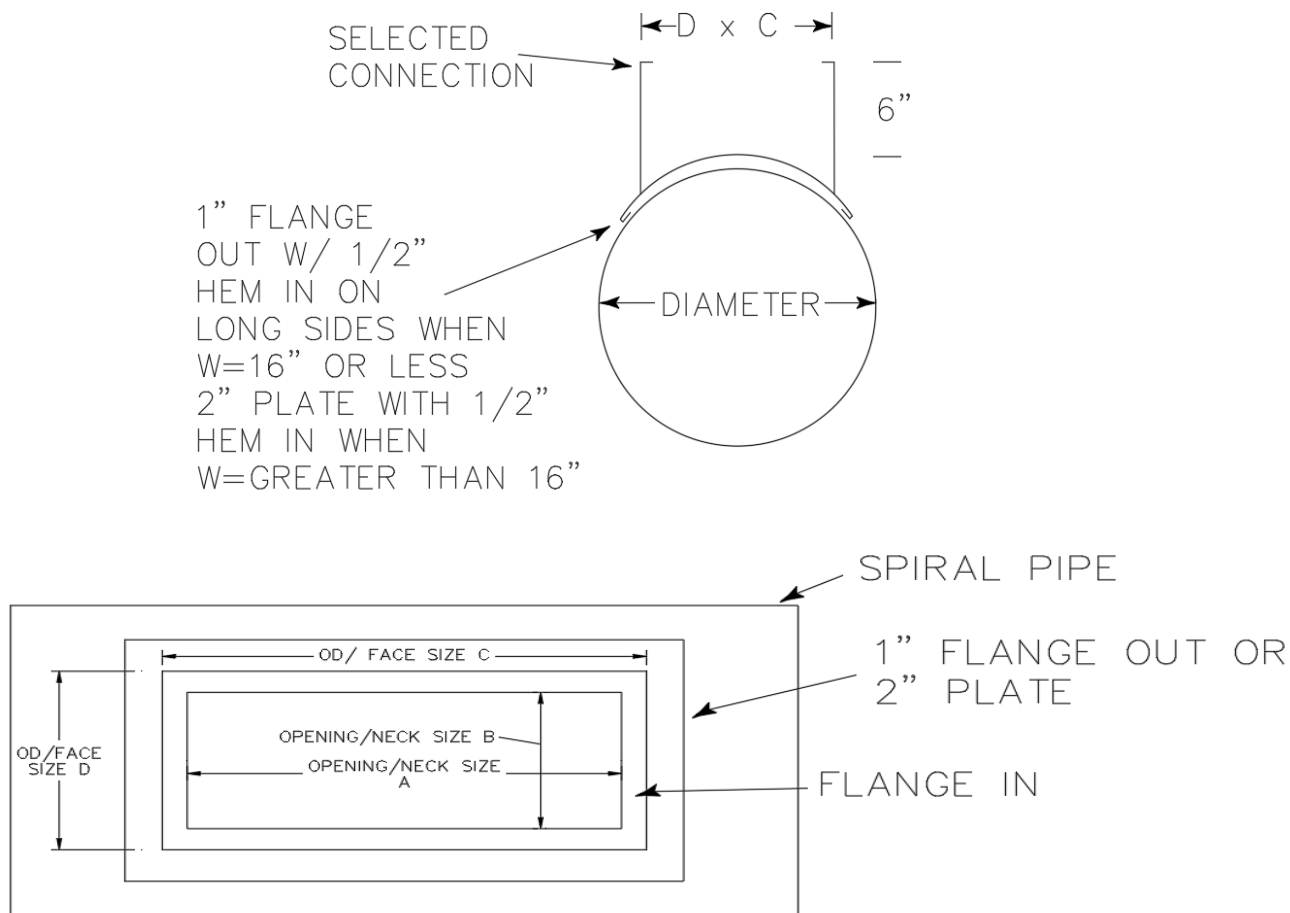

REGISTER BOX SQUARE END SADDLE

- **SPOT WELDED SEAMS USED ON BOXES**
- **STANDARD RECTANGULAR CONNECTION IS FLANGE IN**
- **ALTERNATE CONNECTIONS AVAILABLE: SLIP AND DRIVE, TDC, OR PREMANUFACTURED FLANGE FOR RECTANGULAR END**



ROUND TAPS OFF FLAT SURFACES

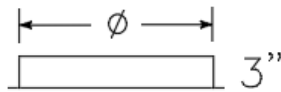

STRAIGHT STICK-ON

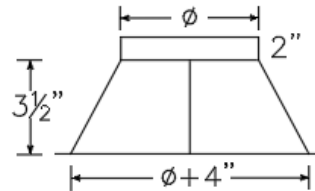

CONICAL STICK-ON

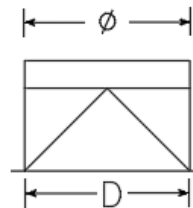
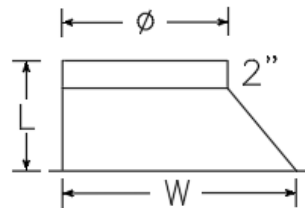

HIGH EFFICIENCY SIDE TAKE OFF

- **ALL TAPS HAVE 3/4" FLANGE OUT WITH 1/8" THICK GASKET.**
- **45 DEGREE LATERAL TAPS AVAILABLE**
- **INSTALLED DAMPERS AVAILABLE (SEE DAMPER SHEET FOR DETAILS)**



TEES AND CROSSES

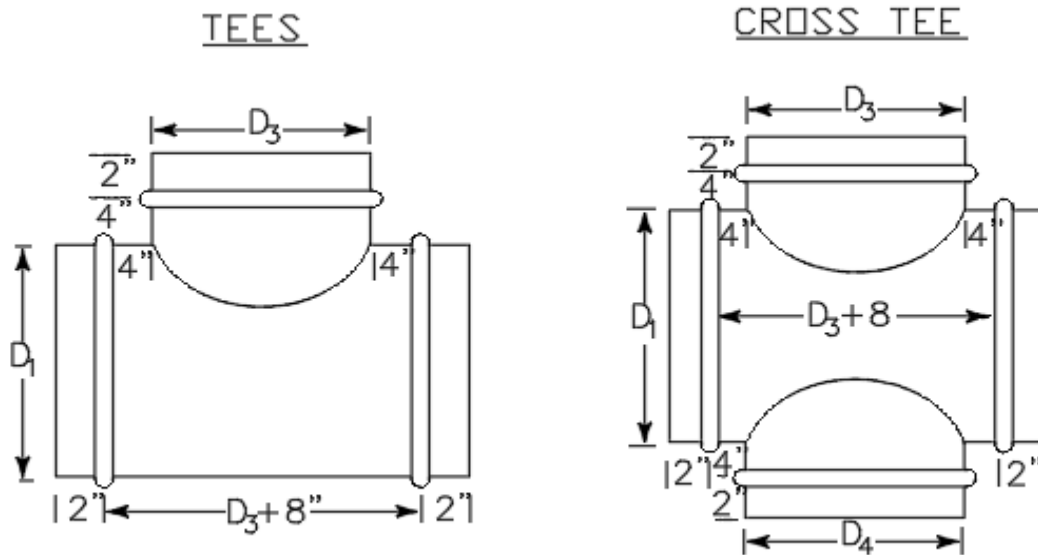

- **SEALED, TACK WELDED SEAMS, STITCH WELDED LONGITUDINAL SEAMS**
- **CONICAL, SHOE STYLE, 45 DEGREE LATERAL TEES AND CROSSES AVAILABLE**
- **REDUCING TEES AND LATERALS ALSO AVAILABLE**



ROUND DAMPERS

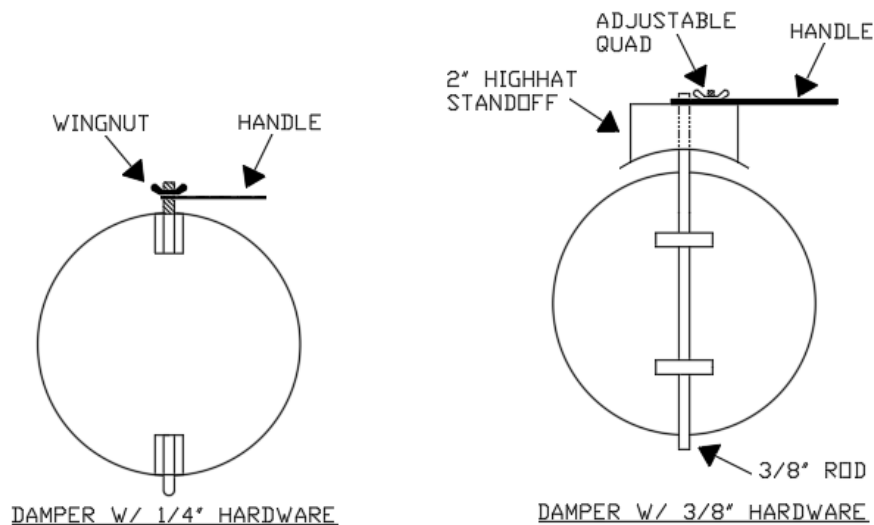

- **DAMPER AVAILABLE IN SLEEVES, LOOSE, OR INSTALLED IN SPIRAL PIPE AND FITTINGS**
- **DAMPERS UP TO 16" ROUND WILL BE 1/4" HARDWARE**
- **DAMPER 18" AND ABOVE WILL BE 3/8" ROD HARWARE**
- **RAPID STANDOFFS AVAILABLE FOR 1/4" HARDWARE**



DUCT LINER INSTALLATION APPLICATION DETAIL

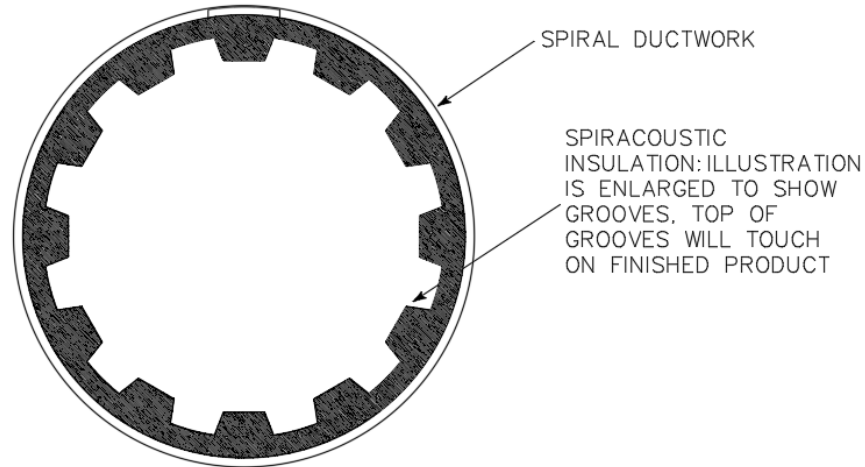

- DUCT BOARD IS CUT TO LENGTH OF SPIRAL DUCT
- CUT PIECE IS THEN GROOVED AT HRANEC CORP
- GROOVED PIECES ARE ROLLED AND TAPED AT THE SEAM
- BOARD IS THEN INSERTED INTO SPIRAL AND HELD IN PLACE BY FRICTION



LINER SPECIFICATIONS



HVAC INSULATION

MICRO-AIRE®MAT-FACED FIBERGLASS DUCT BOARD TYPE 475 & TYPE 800
WITH E³ PALLET™ TECHNOLOGY

DATA SHEET

DESCRIPTION

Micro-Aire® duct board is produced from strong glass fibers, bonded with a thermosetting resin. The airstream side of Micro-Aire duct board features a black fiber glass mat, which minimizes visibility of the duct system at supply air and return air outlets while providing excellent durability in high-velocity conditions. The exterior surface features a fire-resistant foil-scrim-kraft facing extending the full width of the male edge to serve as an integral closure flap for section joints. Micro-Aire duct board is molded with double-density, male/female edges for secure connections.

USES

Micro-Aire duct board is ideal for fabrication into rectangular ductwork for use in heating, ventilating and air-conditioning systems in new commercial or residential construction, or for renovating older sheet metal systems.

STORAGE

Micro-Aire duct board should be kept clean and dry during storage, transport, fabrication, installation, and system operation.

GENERAL PROPERTIES

| | |
|--|---------------------------|
| Operating temperature (max.) – ASTM C411 | 250°F (121°C) |
| Air velocity (max.) – ASTM C1071 | 5000 fpm (25.4 m/sec.) |
| Internal pressure (max.) – UL 181 | 2" w.c. (498 Pa) |
| Fungi resistance – ASTM C1338 | Does not breed or promote |
| Fungi resistance – ASTM G21 | No growth |
| Water vapor transmission – ASTM E96 | < 0.02 Perms |
| Water vapor sorption – ASTM C1104 | < 5% by weight |

STANDARD THICKNESSES AND PACKAGING

To facilitate cost-effective fabrication and installation, Micro-Aire duct board is available in cartons or on pallets in several size configurations. (1½" [38 mm] and 2" [51 mm] thickness available as Type 800 only.)

| Size | | Thickness | |
|-----------|--------------|-----------|------------|
| in | mm | in | mm |
| 48 x 96 | 1219 x 2438 | 1, 1½, 2 | 25, 38, 51 |
| 48 x 120 | 1219 x 3048 | 1, 1½, 2 | 25, 38, 51 |
| 96 x 120* | 2438 x 3048* | 1, 1½ | 25, 38 |

*Wide Board™ available on pallets only. Please reference Purchase Guide for more information.

SURFACE BURNING CHARACTERISTICS

Micro-Aire meets the Surface Burning Characteristics and Limited Combustibility of the following standards:

Standard/Test Method

- ASTM E84
- UL 723
- NFPA 90A and 90B
- Canada: CAN/ULC S102

| | |
|-------------------------------|----|
| Maximum Flame Spread Index | 25 |
| Maximum Smoke Developed Index | 50 |

SPECIFICATION COMPLIANCE

- UL 181 Class 1 Rigid Air Duct Listed
- ICC Compliant
- MEA# 237-86-M
- Universal Building Code (UBC)
- International Mechanical Code (IMC)
- Canada: CGSB 51.10-92 and CAN/ULC-S110M

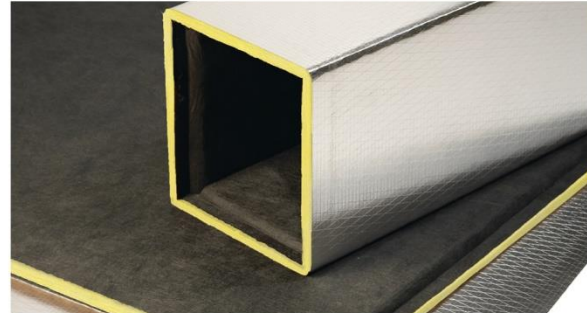

ADVANTAGES

Durable Airstream Surface. Micro-Aire exhibits superior toughness compared to standard fiber glass duct board. It provides increased resistance to damage that can occur from in-shop handling, fabrication, jobsite shipping and installation.

Low Resistance to Air Flow. Micro-Aire duct board has a smooth interior surface that offers minimal resistance to air flow. Air friction data is available from your Johns Manville representative by requesting AHS-165.

Quiet Operation. Fabricated Micro-Aire duct systems noticeably decrease the audibility of crosstalk, equipment noise, and eliminate the sounds associated with the expansion and contraction of sheet metal duct systems.

Will Not Support Microbial Growth. The airstream surface of Micro-Aire duct board is treated with an antimicrobial agent specifically registered with the EPA for HVAC applications to resist potential growth of fungus or bacteria on the airstream surface.

Micro-Aire duct board passes UL 181 mold growth resistance testing. Tests were conducted in accordance with ASTM C1338 and ASTM G21 (fungi testing). Detailed information is available in Johns Manville fact sheet HSE-103FS.

Note: As with any type of surface, microbial growth may occur in accumulated duct system dirt, given certain conditions. This risk is minimized with proper design, filtration, maintenance and operation of the HVAC system.

Cleanability. If cleaning is necessary, the airstream surface may be cleaned using standard industry-recognized dry methods. See the North American Insulation Manufacturers Association (NAIMA) "Cleaning Fibrous Glass Insulated Air Duct Systems."

"Friendlier Feel." The smooth mat facing creates a friendlier surface for fabrication and installation, and reduces exposure to normal construction dust.

Shipped With E³ Pallet™ Technology: The E³ Pallet™ is designed to simplify repurposing our 4x8' and 4x10' pallets into more functional, 48x48" and 48x40" pallets (respectively).

See instructions on page 3.



FLEXURAL RIGIDITY

Micro-Aire duct board is available in stiffness values of 475 and 800 EI. The stiffness or flexural rigidity is the product of Young's Modulus of Elasticity (E) and the Moment of Inertia (I), as determined in accordance with NAIMA AHC-100-74 (REF, ASTM D1037).

HVAC INSULATION

MICRO-AIRE®MAT-FACED FIBERGLASS DUCT BOARD TYPE 475 & TYPE 800
WITH E³ PALLET™ TECHNOLOGY**CLOSURE SYSTEMS**

In order to meet the requirements of UL 181 for a Class 1 Air Duct System, closures meeting the requirements of UL 181A must be used with Micro-Aire. For additional fabrication instruction information, reference AHS-30 or NAIMA Fibrous Glass Duct Construction Standards (www.naima.org)

CLOSURE I**UL 181A-H Closures**

Use tapes listed and labeled in accordance with Standard UL 181A and marked "181A-H." Tapes in compliance with this standard must be imprinted with this information. Heat seal all longitudinal and circumferential joints according to tape manufacturers' recommendations. Center strip over the edge of stapling flap. Staples are not required when automatic closure equipment is used for the longitudinal joint.

CLOSURE II**UL 181A-P Pressure Sensitive Tapes**

Use tapes listed and labeled in accordance with Standard UL 181A and marked "181A-P." Tapes in compliance with this standard must be imprinted with this information.

Use tape that is a minimum 1" (25 mm) wider than the thickness of the board. Apply to all longitudinal and circumferential joints and rub in carefully using a squeegee or similar tool. The tape should be rubbed in until the scrim pattern from the duct board facing shows through the tape. Center tape over the edge of stapling flap. Heat seal if temperature is below 40°F (4°C).

CLOSURE IV**UL 181A-M Mastic Closure**

Use mastics listed and labeled in accordance with Standard UL 181A and marked "181A-M." Before applying, stir the mastic thoroughly. Brush on a 4" (102 mm) wide coating over the stapled flap. Embed the open mesh glass tape in the mastic. Apply an additional coat of mastic over the tape, filling in the mesh

LIMITATION OF LIABILITY

If the closure system used is not one of the approved systems noted above, and if application is not in accordance with the tape or glass fabric and mastic manufacturer's stated procedures, the UL 181 Class 1 air duct rating and the Johns Manville product warranty are void.

RECYCLED CONTENT**MAXIMUM UNREINFORCED DUCT DIMENSIONS**

| Thickness | Internal Pressure in. water column | Positive inches | Negative inches |
|------------------------------|---------------------------------------|--------------------|--------------------|
| Type 475 1" | 0.5 | 36 | 34 |
| | 1.0 | 24 | 22 |
| | 2.0 | 15 | 14 |
| Type 800 1½", 2" | 0.5 | 40 | 38 |
| | 1.0 | 26 | 22 |
| | 2.0 | 18 | 16 |
| Thickness | Internal Pressure Pa | Positive mm | Negative mm |
| Type 475 25 mm | 125 | 914 | 864 |
| | 249 | 610 | 559 |
| | 498 | 381 | 356 |
| Type 800 38, 51 mm | 125 | 1016 | 965 |
| | 249 | 660 | 610 |
| | 498 | 457 | 407 |

This table summarizes span/pressure limitations for unreinforced duct. For larger duct sizes, see The Pocket Installer, AHS-3.

THERMAL CONDUCTIVITY

| Thickness | | Mean Temp. @ 75°F (24°C) | |
|-----------|----|---------------------------------|-------|
| in | mm | Btu•in/(hr•ft ² •°F) | W/m•° |
| 1 | 25 | 0.23 | 0.033 |
| 1½ | 38 | 0.23 | 0.033 |
| 2 | 51 | 0.23 | 0.033 |

Conductivity per ASTM C518.

THERMAL PERFORMANCE

| Thickness | | R-value | |
|-----------|----|------------------------------|----------------------|
| in | mm | (hr•ft ² •°F)/Btu | m ² •°C/W |
| 1 | 25 | 4.3 | 0.76 |
| 1½ | 38 | 6.5 | 1.15 |
| 2 | 51 | 8.7 | 1.53 |

**MICRO-AIRE SOUND ABSORPTION COEFFICIENTS
(TYPE "A" MOUNTING)**

| Type | Thickness | | Sound Absorption Coefficient at Frequency | | | | | | |
|------|-----------|----|---|------|------|------|------|------|------|
| | in | mm | 125 | 250 | 500 | 1000 | 2000 | 4000 | NRC |
| 475 | 1 | 25 | 0.07 | 0.25 | 0.63 | 0.90 | 0.97 | 1.00 | 0.70 |
| 800 | 1½ | 38 | 0.10 | 0.42 | 0.91 | 1.04 | 1.04 | 1.04 | 0.85 |
| 800 | 2 | 51 | 0.17 | 0.63 | 1.10 | 1.05 | 1.04 | 1.06 | 0.95 |

Coefficients were tested in accordance with ASTM C423 and ASTM E795.

ISO 9000 CERTIFICATION

Johns Manville mechanical insulation products are designed, manufactured and tested in our own facilities, which are certified and registered to stringent ISO 9001:2015 series quality standards. This certification, along with regular, independent third-party auditing for compliance, is your assurance that Johns Manville products deliver consistent high quality.